

# Bahnhofskneipe mit Biergarten

# POLA G

Station-Pub with beer garden  
Bistrot de gare avec brasserie en plein air  
Stationskroeg met tuincafé

Art. Nr. 331013



Sa. Nr. 410 224 0

- (D)**
- Verwenden Sie nur POLA G-Cement.
  - Machen Sie sich vor dem Zusammenbau gut mit den Einzelteilen des Bausatzes vertraut. Trennen Sie die Einzelteile erst dann ab, wenn sie gebraucht werden.
  - Verwenden Sie beim Zusammenbau wenig Klebstoff. Sie werden dann mehr Freude an einem sauberem Modell haben.
  - Sollte trotz werkseitiger sorgfältiger Prüfung ein Teil fehlen oder fehlerhaft sein, kreuzen Sie bitte das Teil in der Anleitung an und schicken Sie diese bitte an:  
**Gebr. FALLER GmbH, Abt. Kundendienst, kundendienst@faller.de, Kreuzstraße 9, D-78148 Gütenbach.**  
Sie erhalten dann umgehend Ersatz.
- (GB)**
- Use POLA G-Cement only.
  - Familiarize yourself well with the components of the kit before assembly. Do not break off the components until the moment you need them.
  - Use glue sparingly on assembly, then you will enjoy your neat model even more.
  - If a part is missing or defective despite careful checking at the factory, please mark the part concerned in your instructions and send it to:  
**Gebr. FALLER GmbH, Abt. Kundendienst, kundendienst@faller.de, Kreuzstraße 9, D-78148 Gütenbach, Germany.**  
You will receive replacement promptly.
- (F)**
- N'utilisez que la colle POLA G -Cement.
  - Avant l'assemblage, familiarisez vous avec les différentes pièces du jeu de construction. Ne séparer les pièces particulières qu'au moment de les utiliser.
  - Utiliser aussi peu de colle que possible pour l'assemblage, vous aurez d'autant plus de plaisir avec un modèle propre.
  - Si, malgré un contrôle soigneux à l'usine, une pièce devait manquer ou être défectueuse, marquer cette pièce d'une croix dans les instructions et envoyer ces dernières à:  
**Gebr. FALLER GmbH, Abt. Kundendienst, kundendienst@faller.de, Kreuzstraße 9, D-78148 Gütenbach ( R.F.A. ).**  
On vous la remplacera aussitôt.
- (NL)**
- Gebruik uitsluitend POLA G -cement.
  - Zorg da u vóór de montage goed weet uit welke onderdelen het bouwpakket bestaat. Maak de onderdelen pas los als u ze gaat gebruiken.
  - Gebruik bij de montage slechts weinig lijm. U zult dan meer plezier beleven aan een schoon model.
  - Mist u ondanks zorgvuldige fabrikantencontrole toch een onderdeel of is een onderdeel beschadigd, kruis dan het desbetreffende onderdeel aan in de handleiding en stuur dit s.v.p. aan:  
**Gebr. FALLER GmbH, Abt. Kundendienst, kundendienst@faller.de, Kreuzstraße 9, D-78148 Gütenbach, Duitsland.**  
Het wordt dan direct vervangen en naar u opgestuurd.



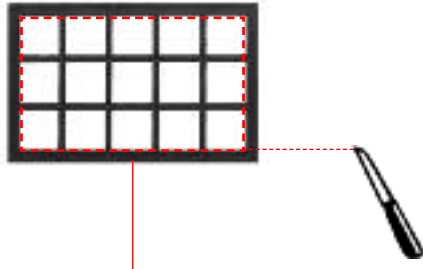

(A)

05-11

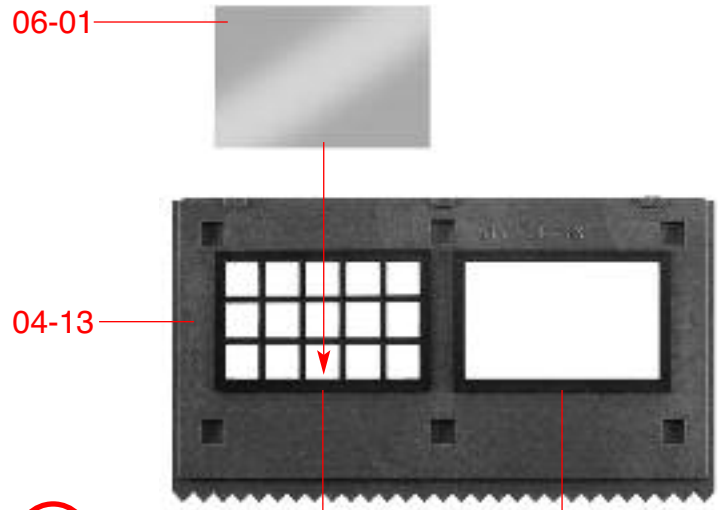

(B)

04-13

05-11

(A)

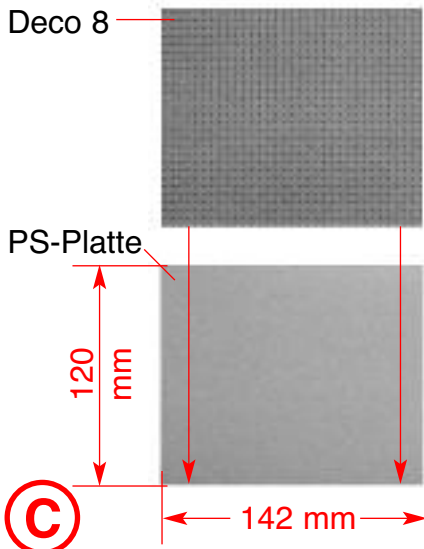

(C)

Deco 8

PS-Platte

120 mm

142 mm

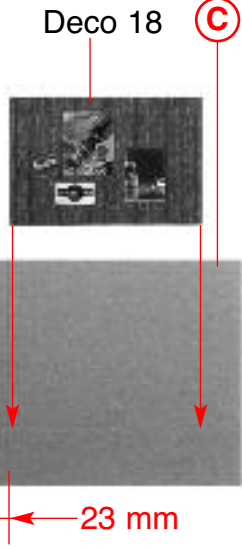

(D)

Deco 18

32 mm

23 mm

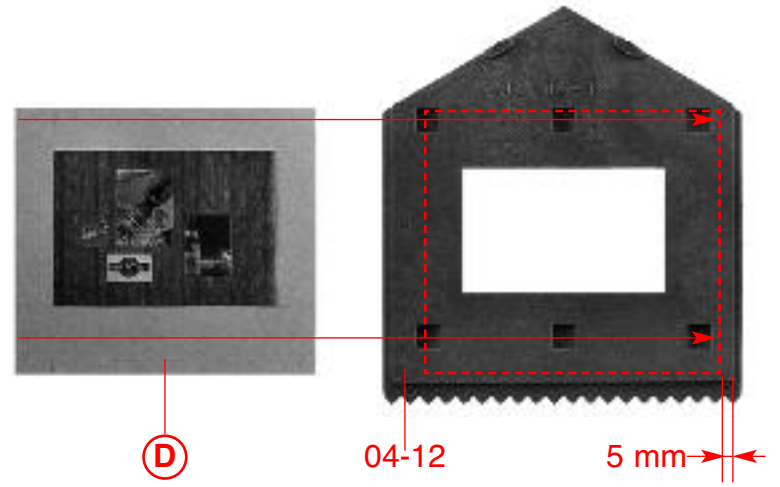

(E)

(D)

04-12

5 mm

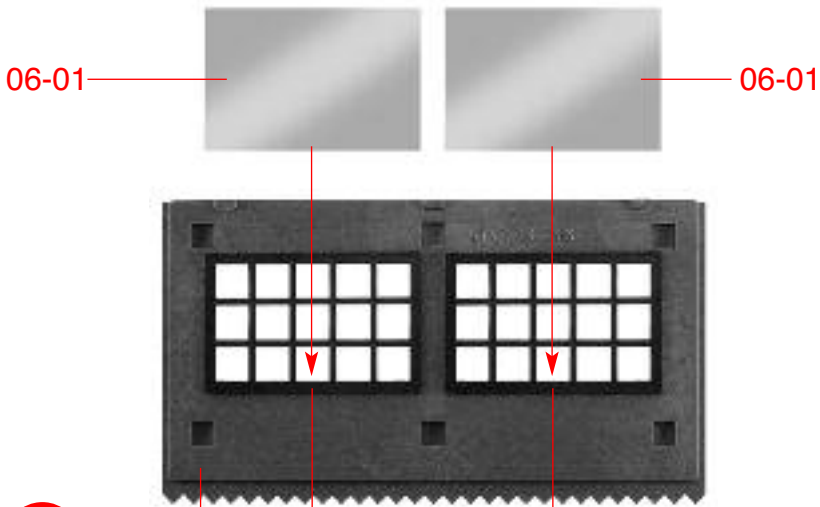

(F)

06-01

06-01

04-13

05-11

05-11

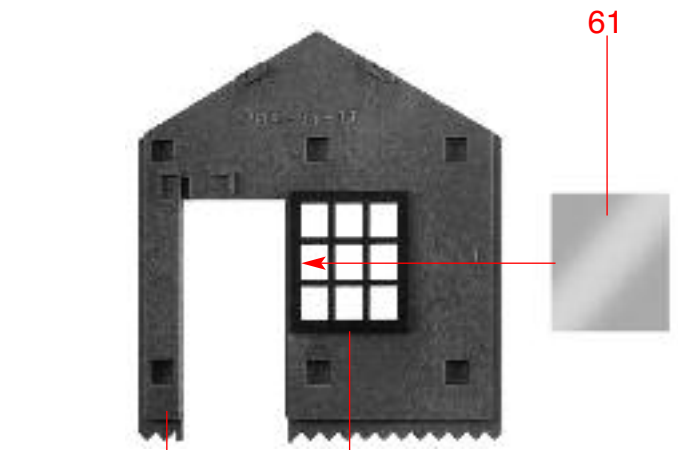

(G)

61

04-11

05-12

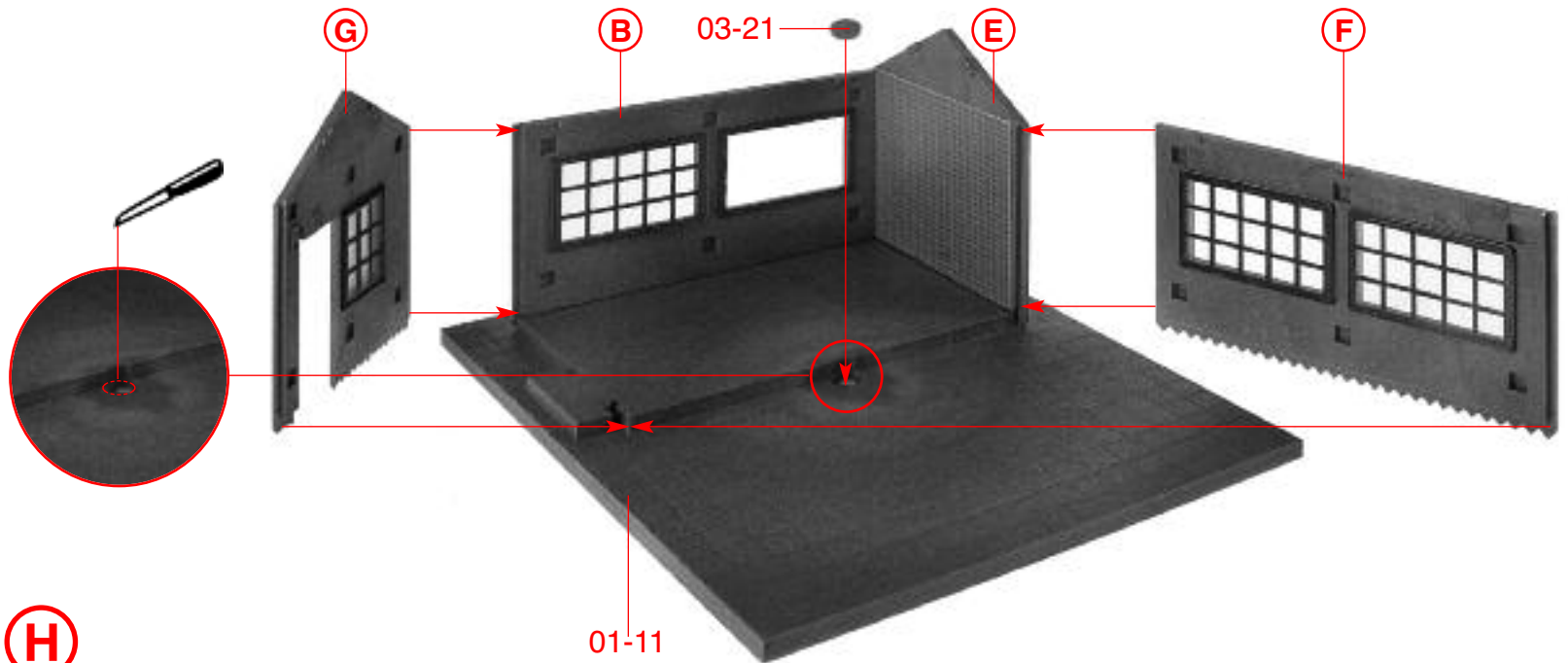

(H)

03-21

(B)

(E)

(F)

01-11

62

Deco 4

06-17



I

06-13

J

Deco 10  
06-18



Deco 12

I

K

J nicht kleben  
do not glue  
ne pas coller  
niet lijmen

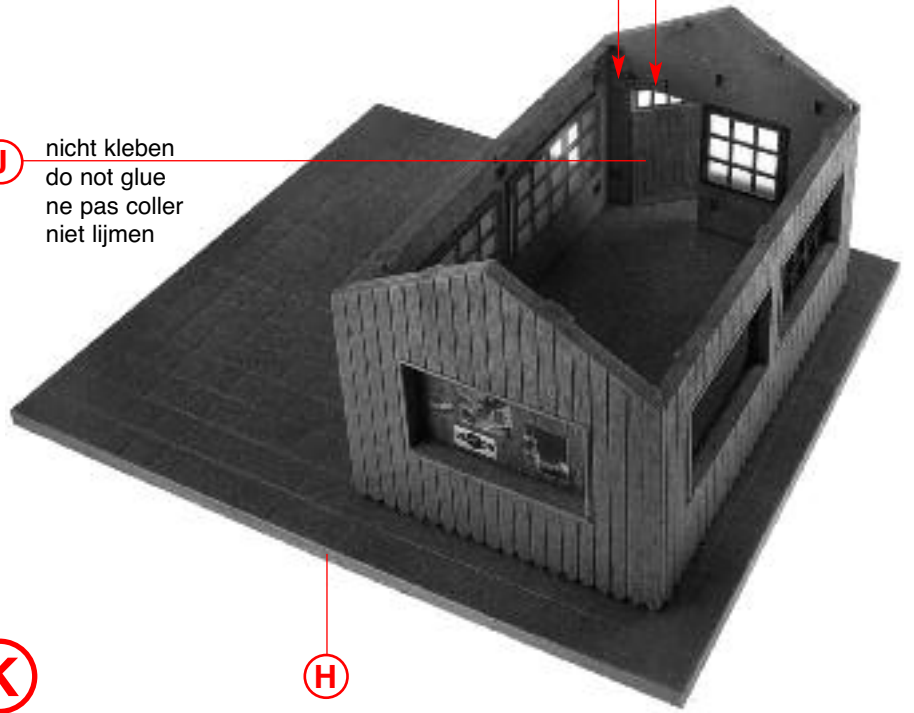

H

2/18

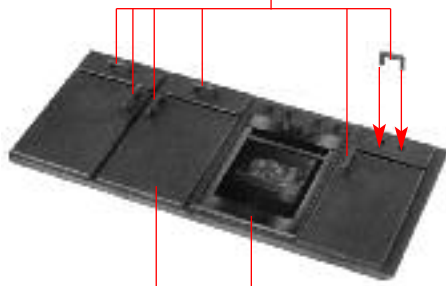

L

2/31 Deco 7

2/18

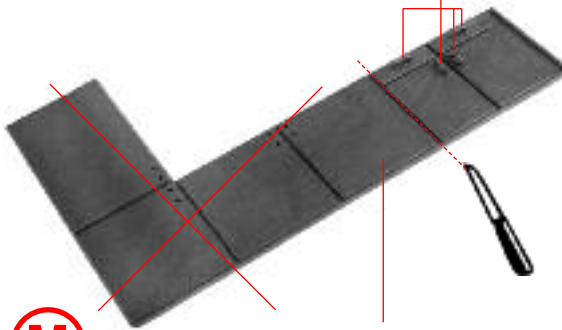

M

2/30

2/27

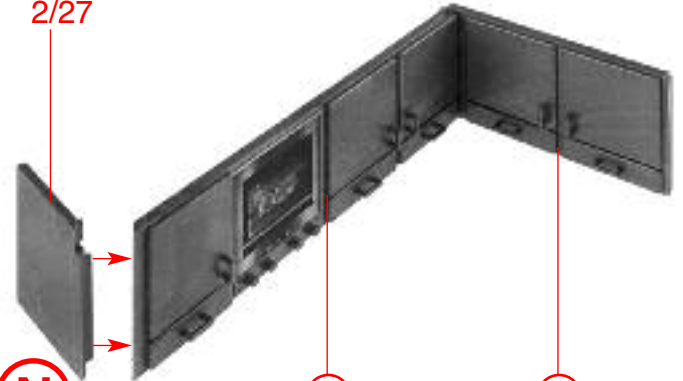

N

L

M

2/25

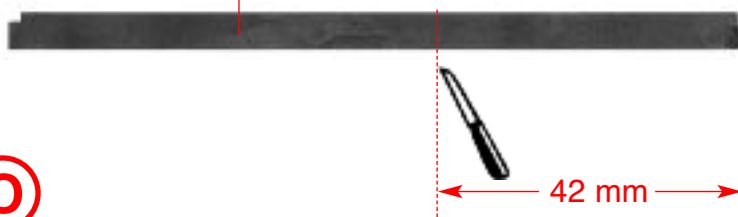

O

42 mm

O



P

N

2/26

35 mm

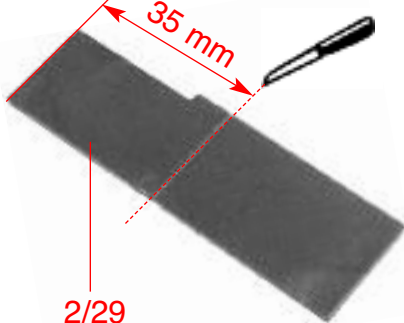

Q

2/29

R

Q

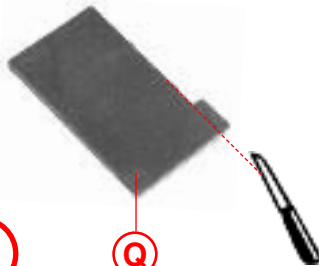

S

R

P

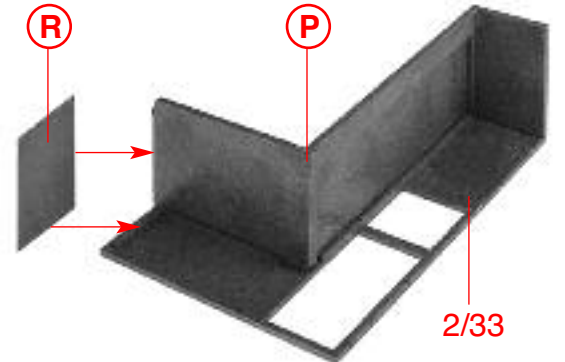

2/33

2/5

2/7

2/6

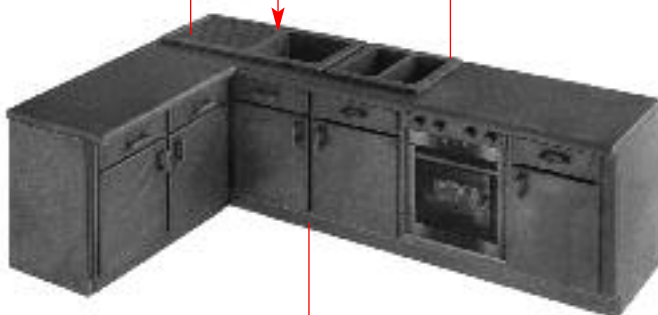

T

S

3 x 04-13

2/8

2 x 2/19  
04-16

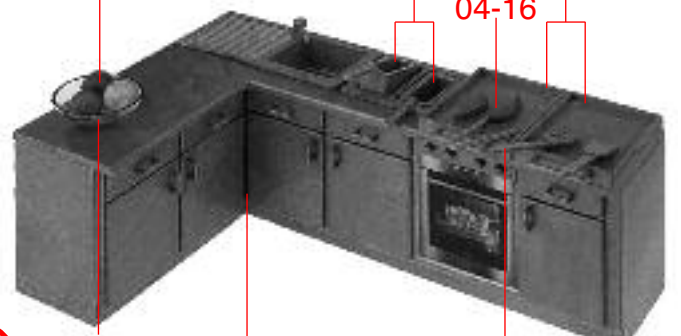

U

3/4

T

2/11 + 2/12 + 2/13

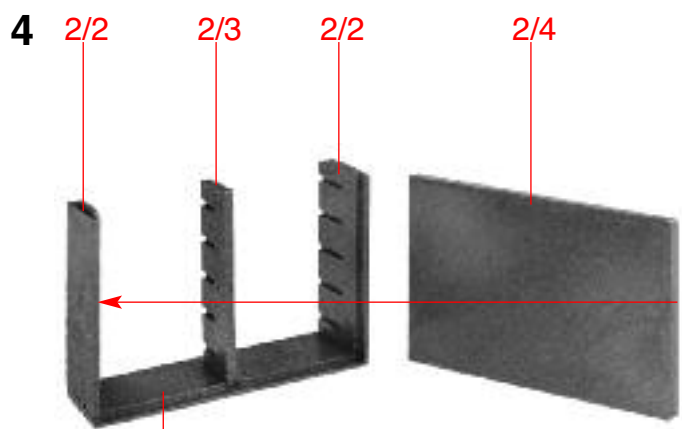

(W)

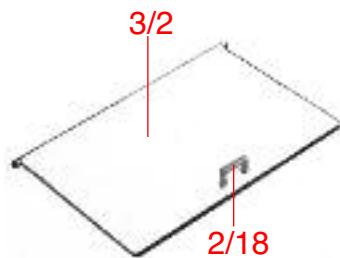

(X)

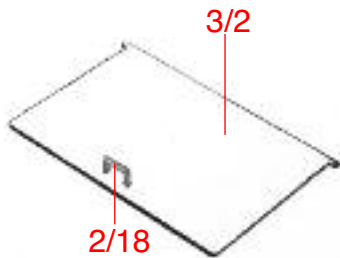

(Y)

(V)

(V)

(a)

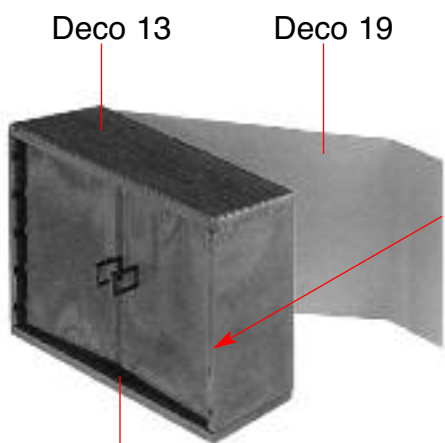

(Y)

(b)

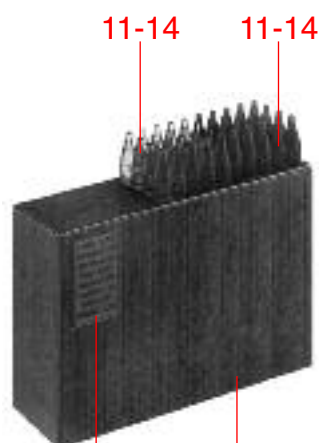

Deco 6

(a)

(c)

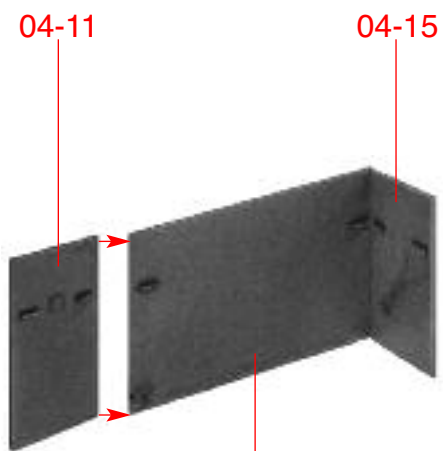

04-14

(d)



(c)

04-13

(e)

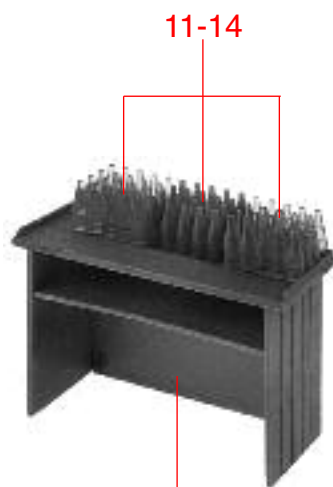

(d)

(f)

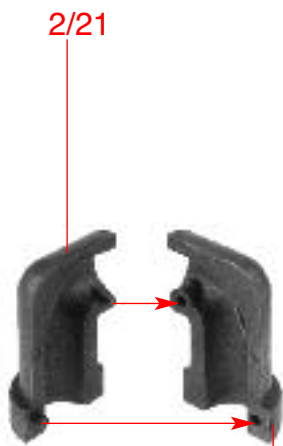

2/22

(g)



2/20

(h)

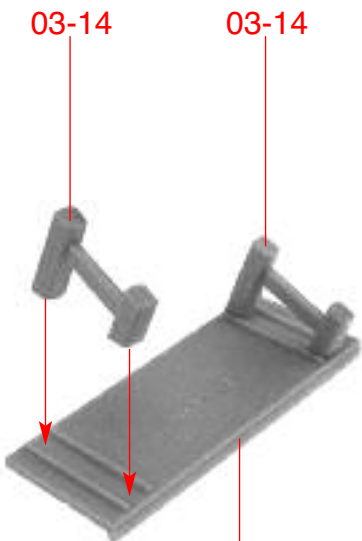

03-13

(i)



(h)

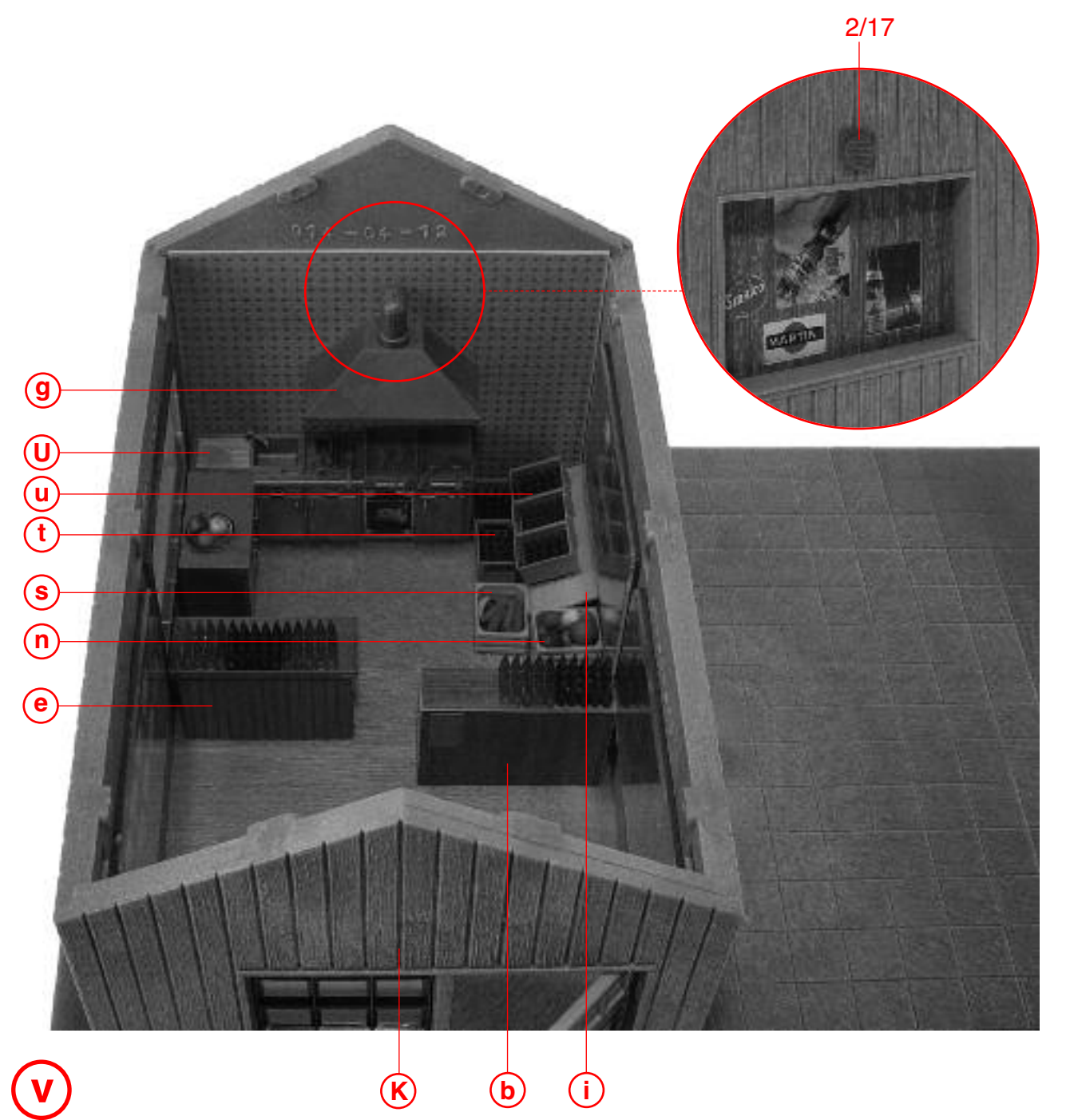
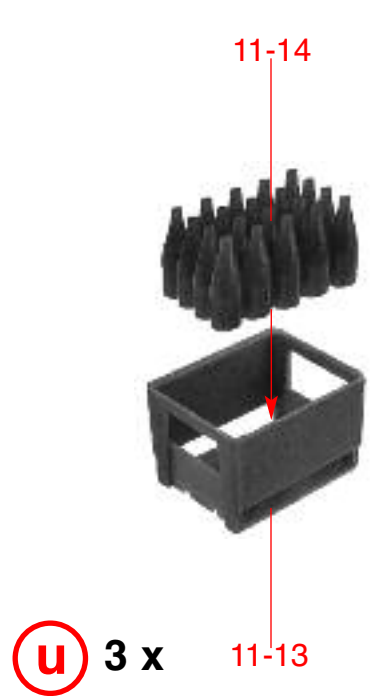
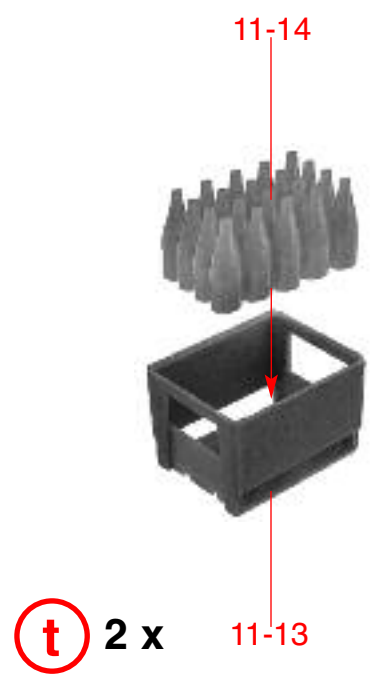
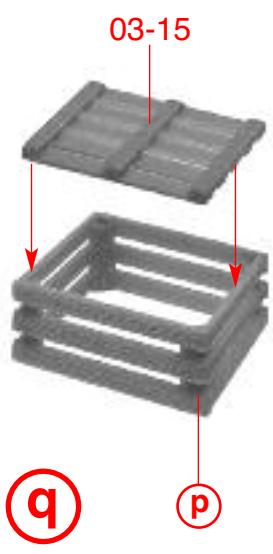
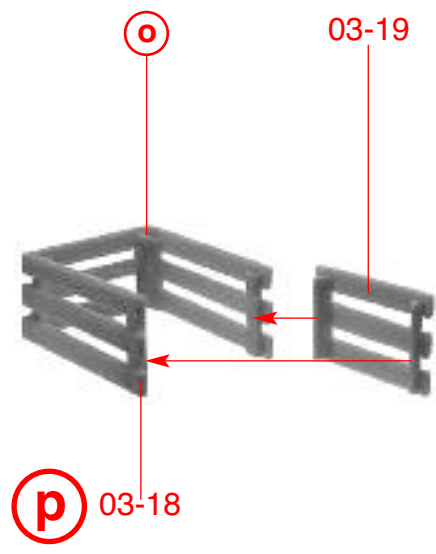
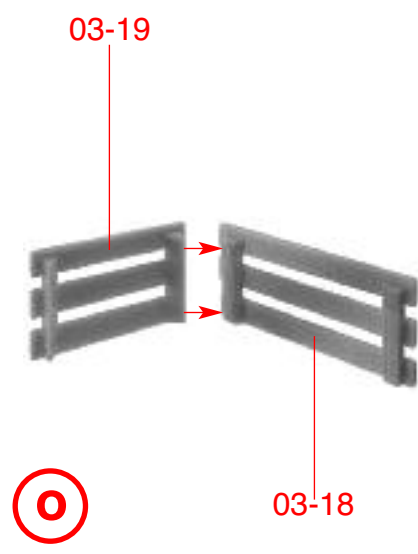
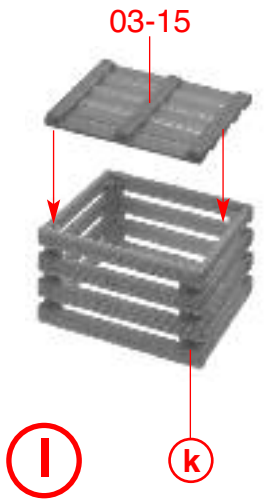
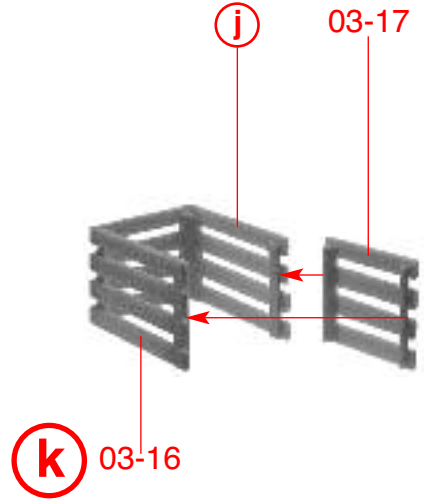
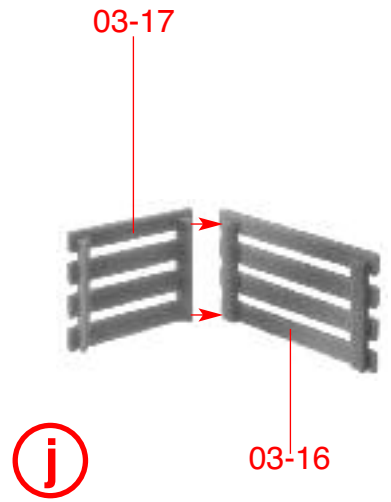

6

06-11 06-12



**(A)** 8 x

06-13

06-13



**(B)** 8 x

**(A)**

Deco 9



**(C)** 8 x

**(B)**

06-15

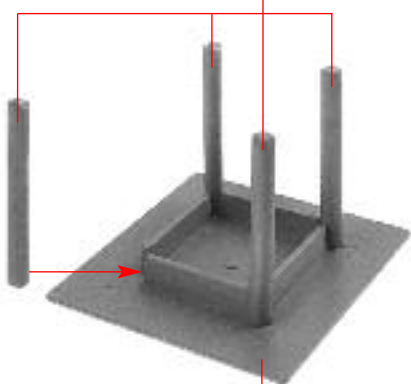

**(D)** 2 x

06-14

Deco 2



**(E)** 2 x

**(D)**

**(E)**

**(C)**

**(E)**

**(C)**

**(C)**

**(V)**

**(F)**

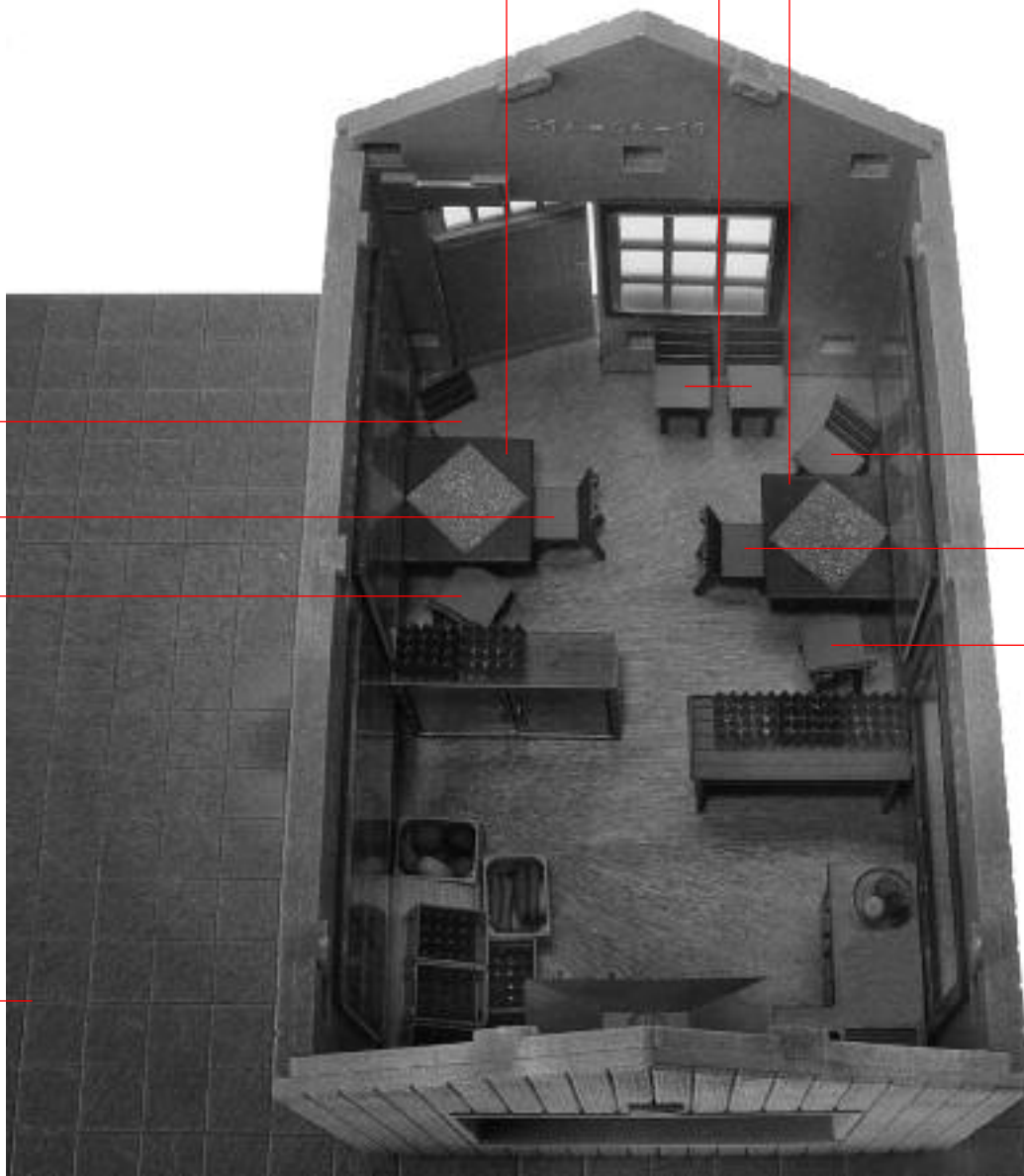

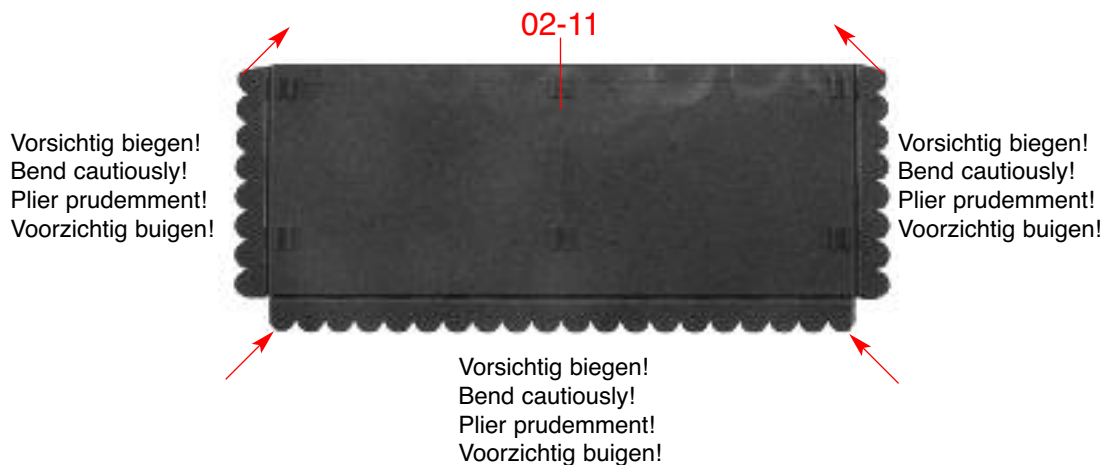

G



H

G

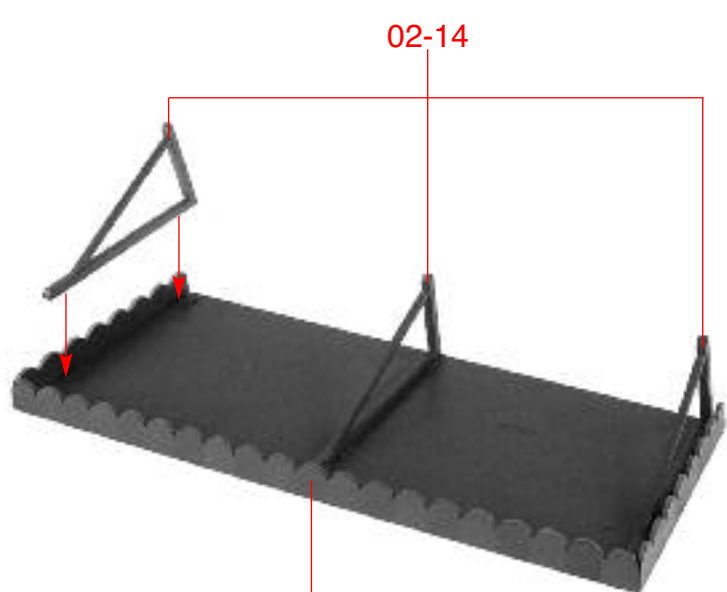

I

H

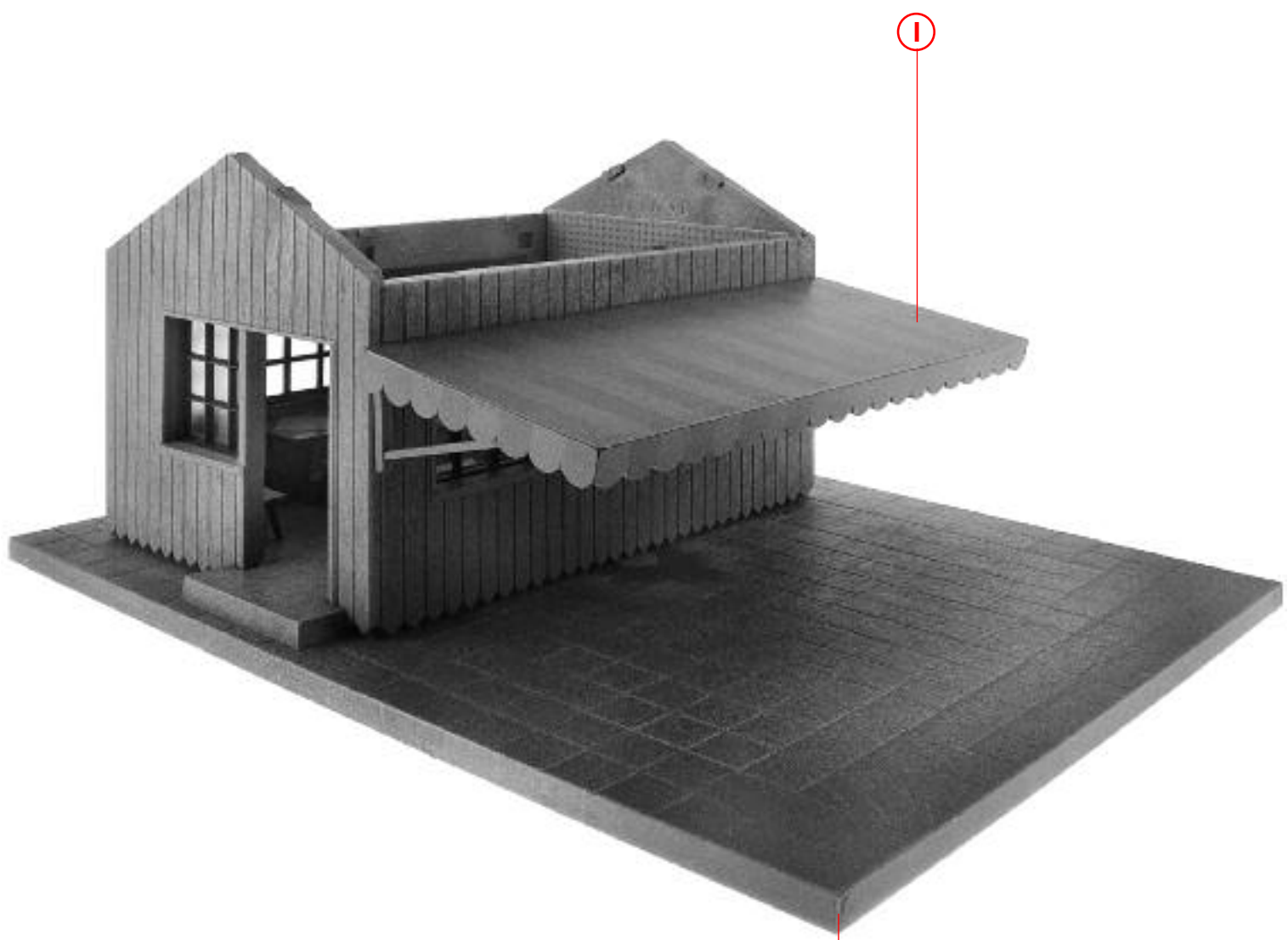

J

F

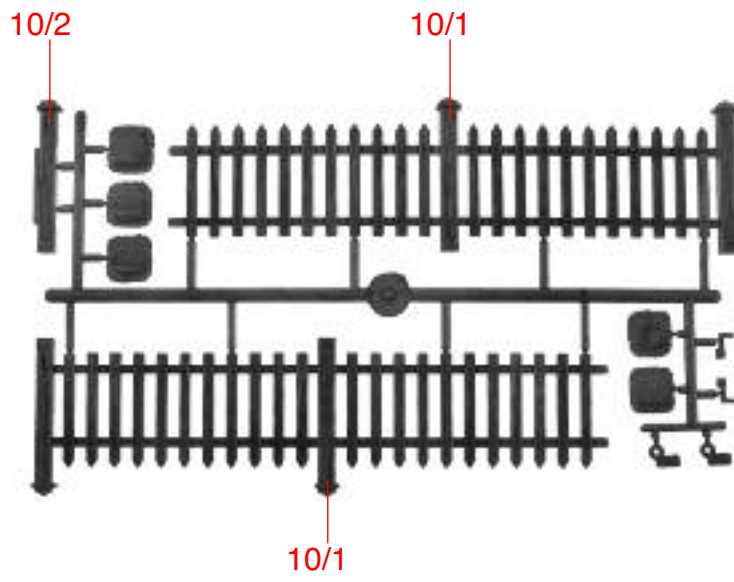

**10** 2 x

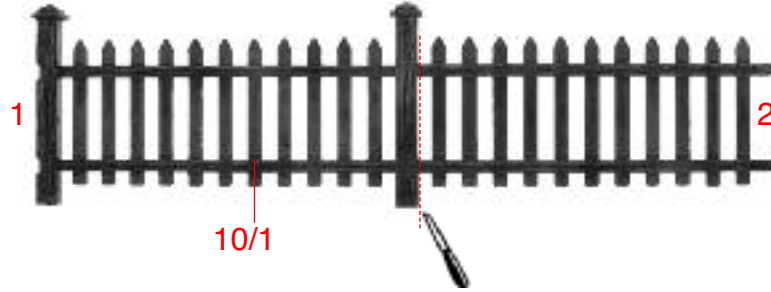

**K** 2 x

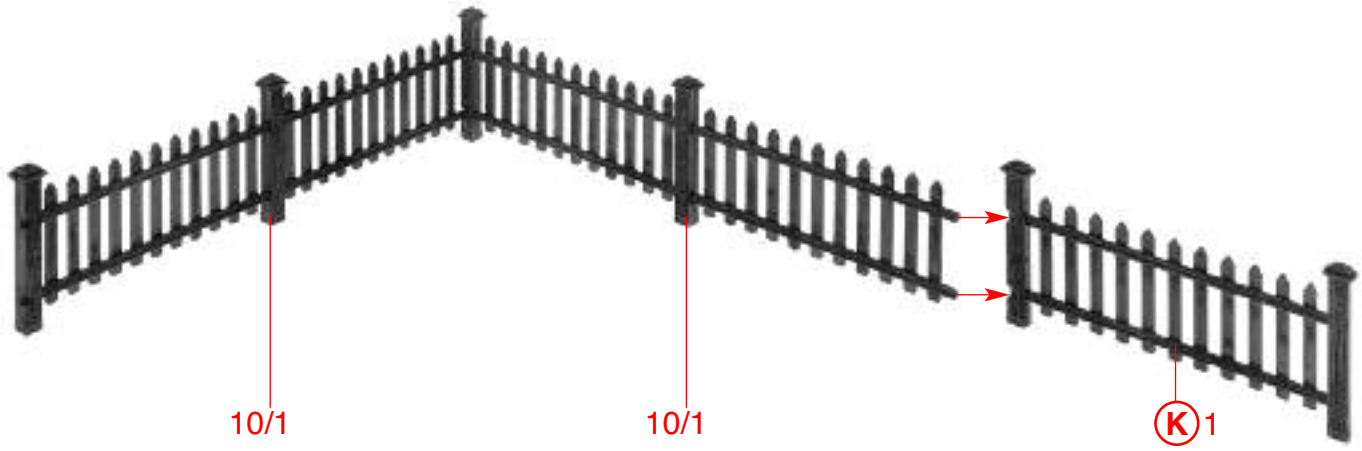

**L**

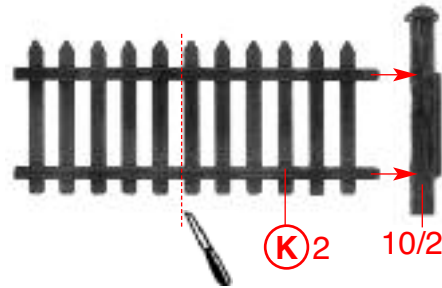

**M**

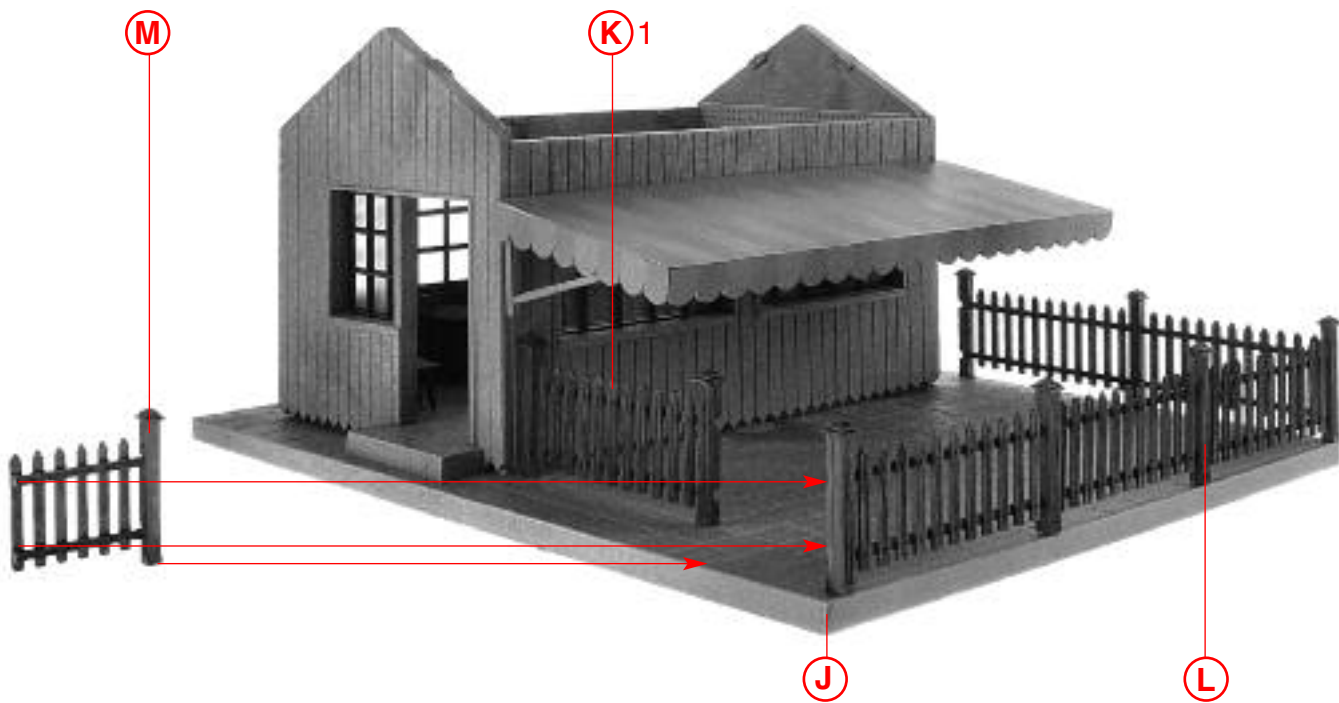

**N**



Deco 14 + 15

03-11

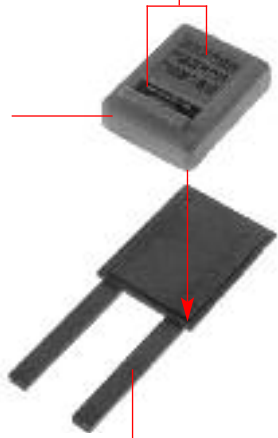

2/23

**O**

01-20

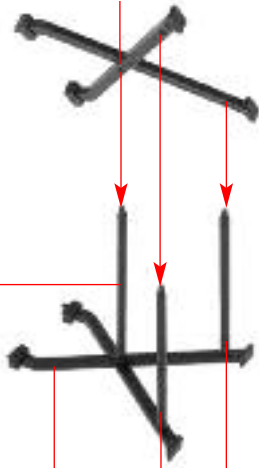

01-23

**P** 2 x 01-19 01-13 01-13

**P**

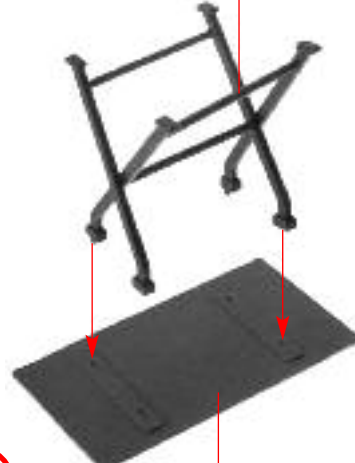

02-17

**Q** 2 x

Deco 2



**R** 2 x **Q**

01-21

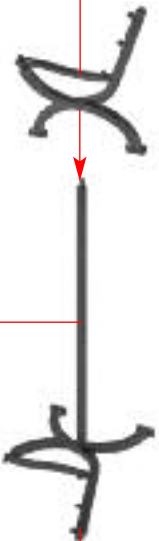

01-14

01-22

**S** 2 x

02-14



02-16

**T** 2 x

**S**



**U** 2 x

**T**

01-17



01-12

01-18

**V** 8 x

**O**

**N**

**R**

**U**

**U**

**R**

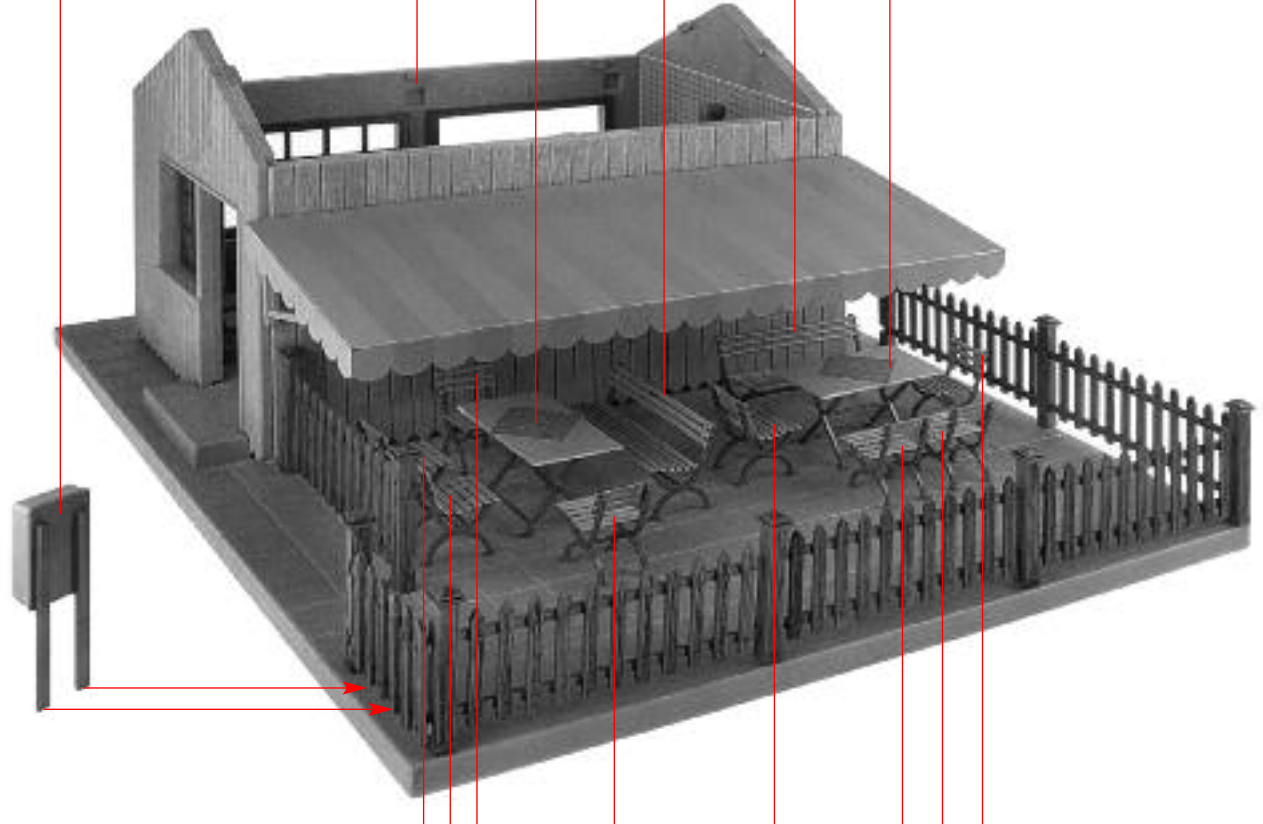

02-11

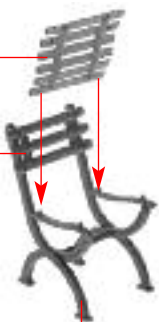

02-19

**W** 8 x

**V**



**X** 8 x

**W**

**Y**

**X**

10 02-12

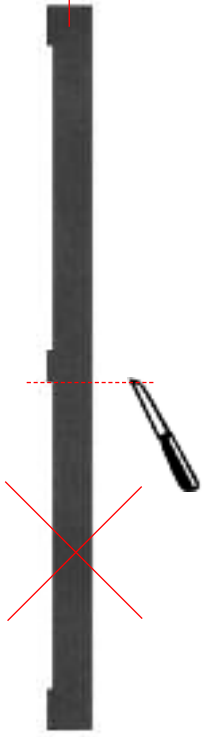

(a)

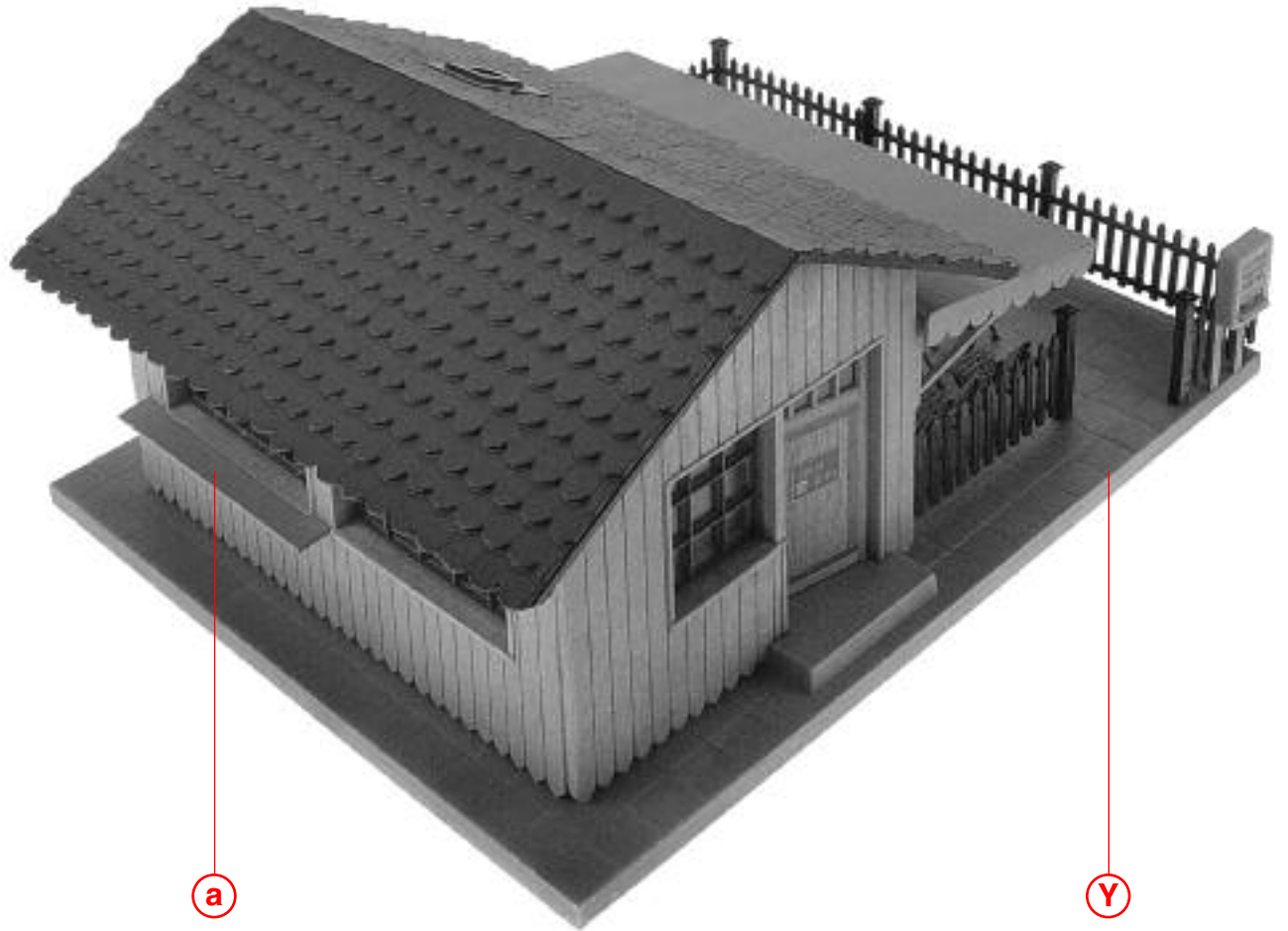

(b)

(a)

(Y)

04-12

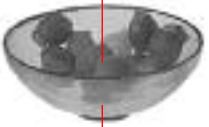

(c)

3/4

04-11



(d)

3/5

Deco 5



(e)

05-20

Poly-Platte



(f)

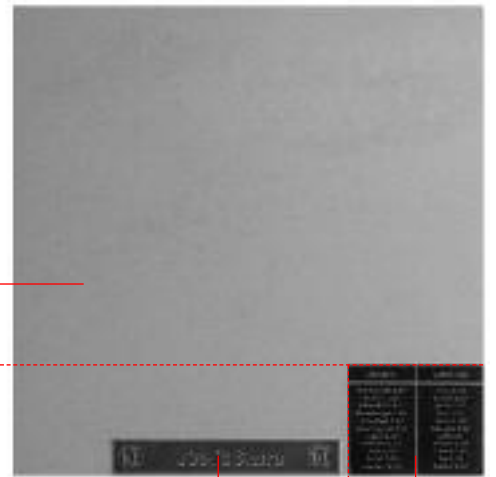

Deco 16

Deco 17

2 x 3/6 + 04-17 + 04-18 + 04-22

(f)

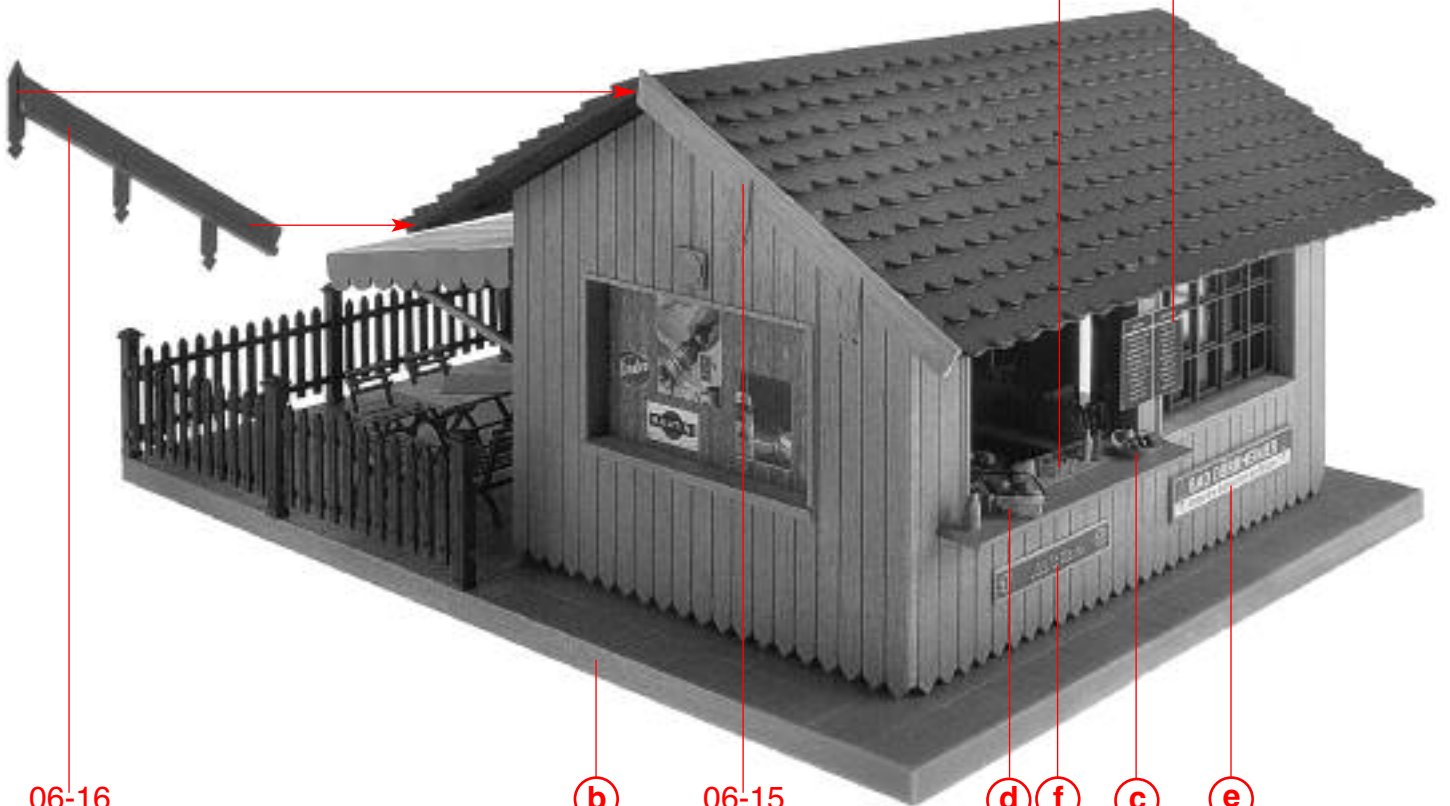

(g)

06-16

(b)

06-15

(d)

(f)

(c)

(e)

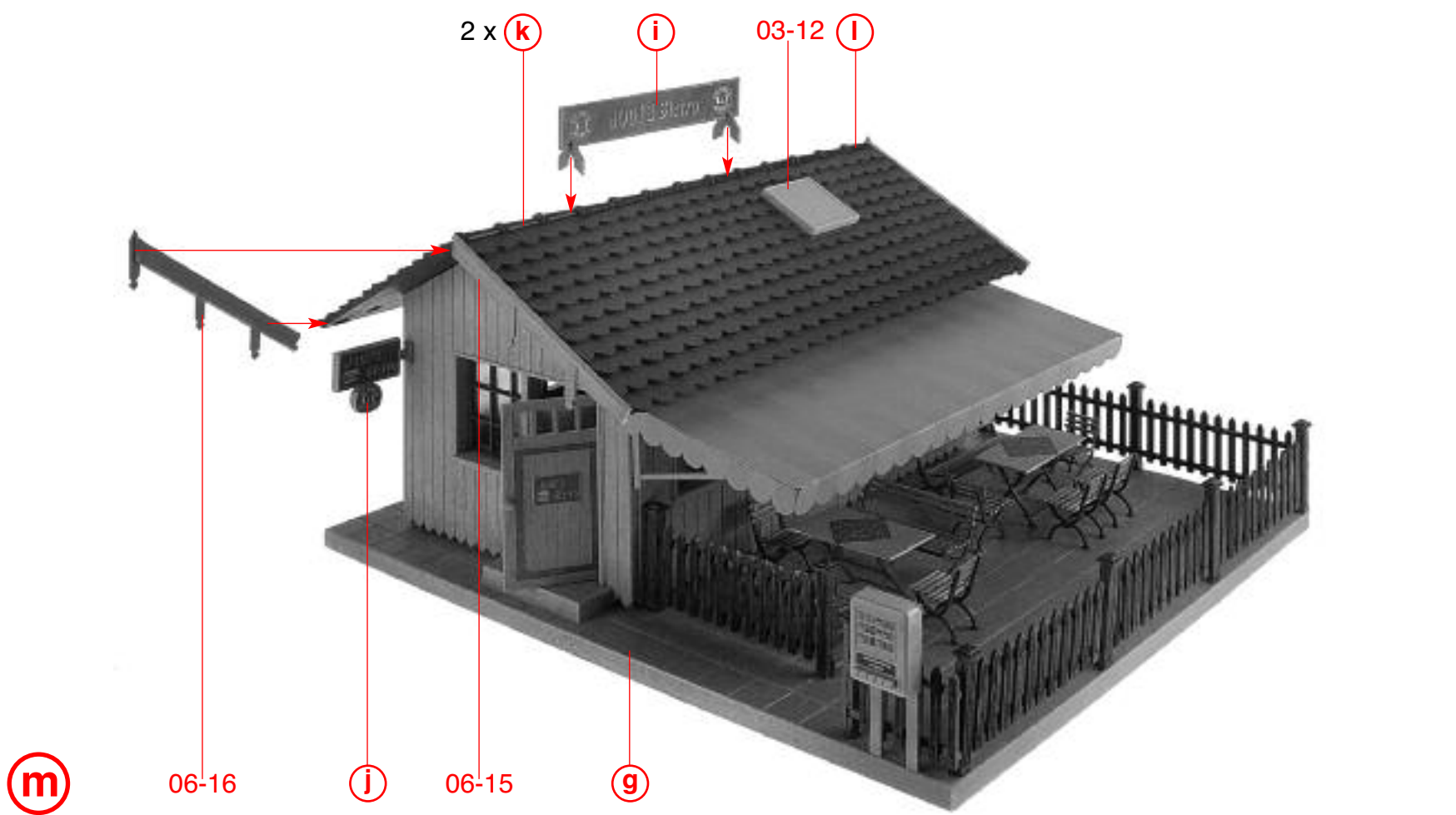
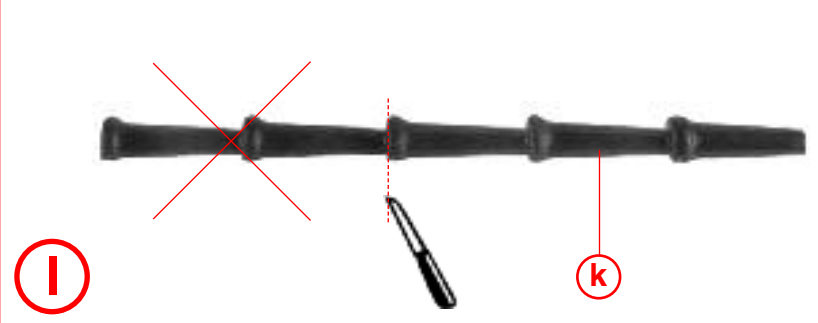
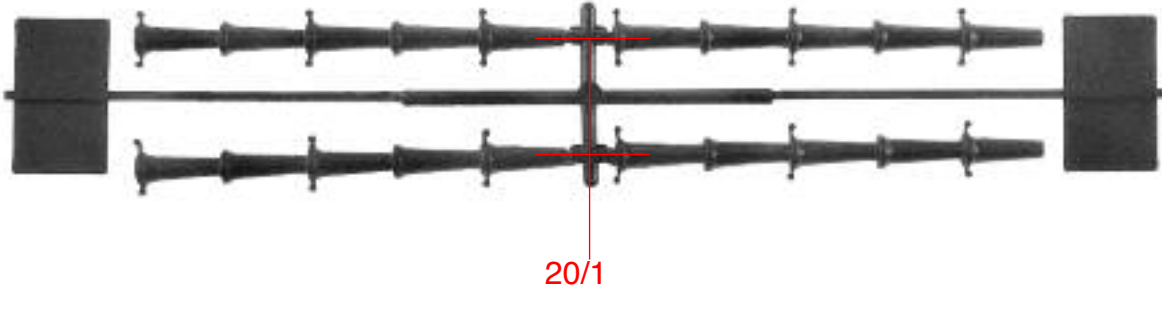
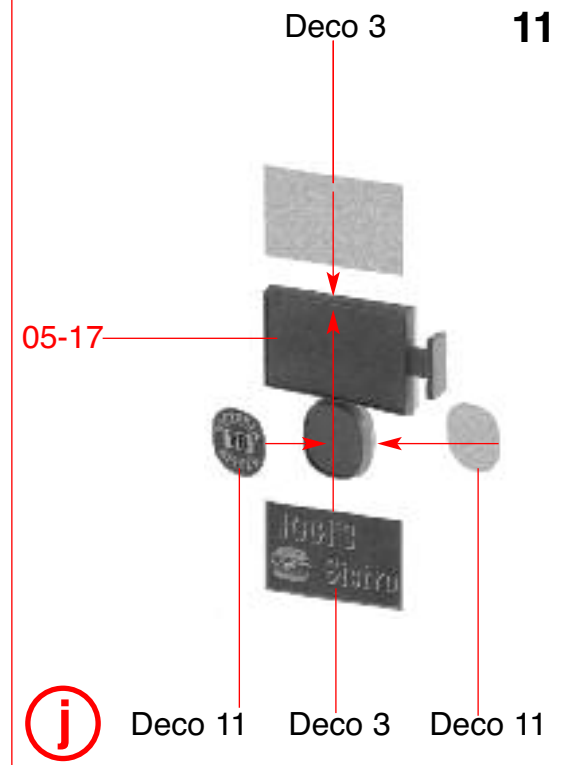
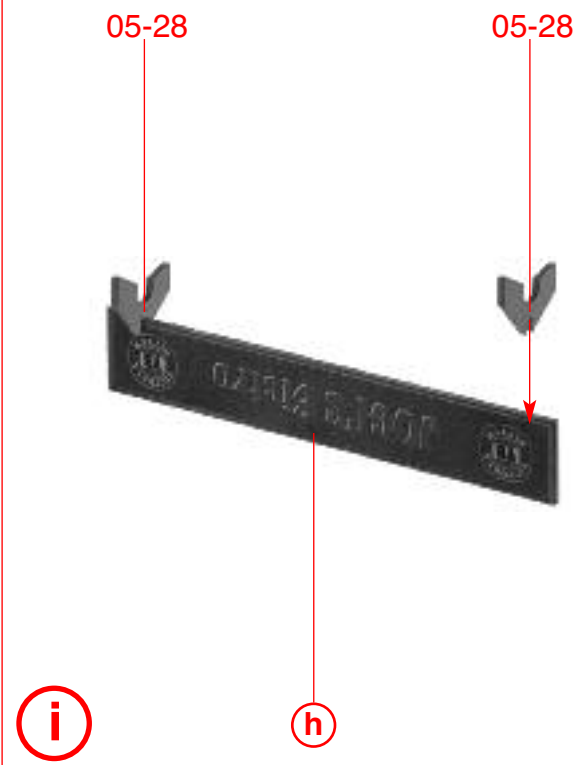
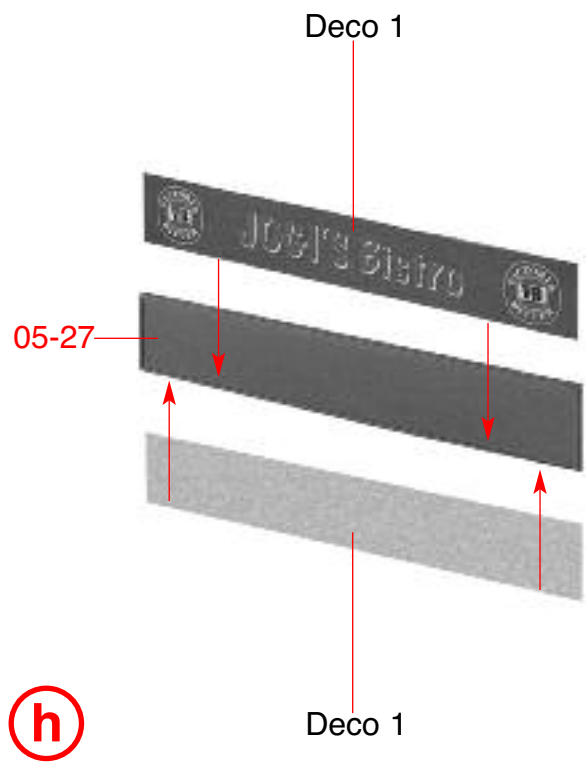

Inhalt	Tüte	Contents	bag
Contenu	sachet	Inhoud	zakje

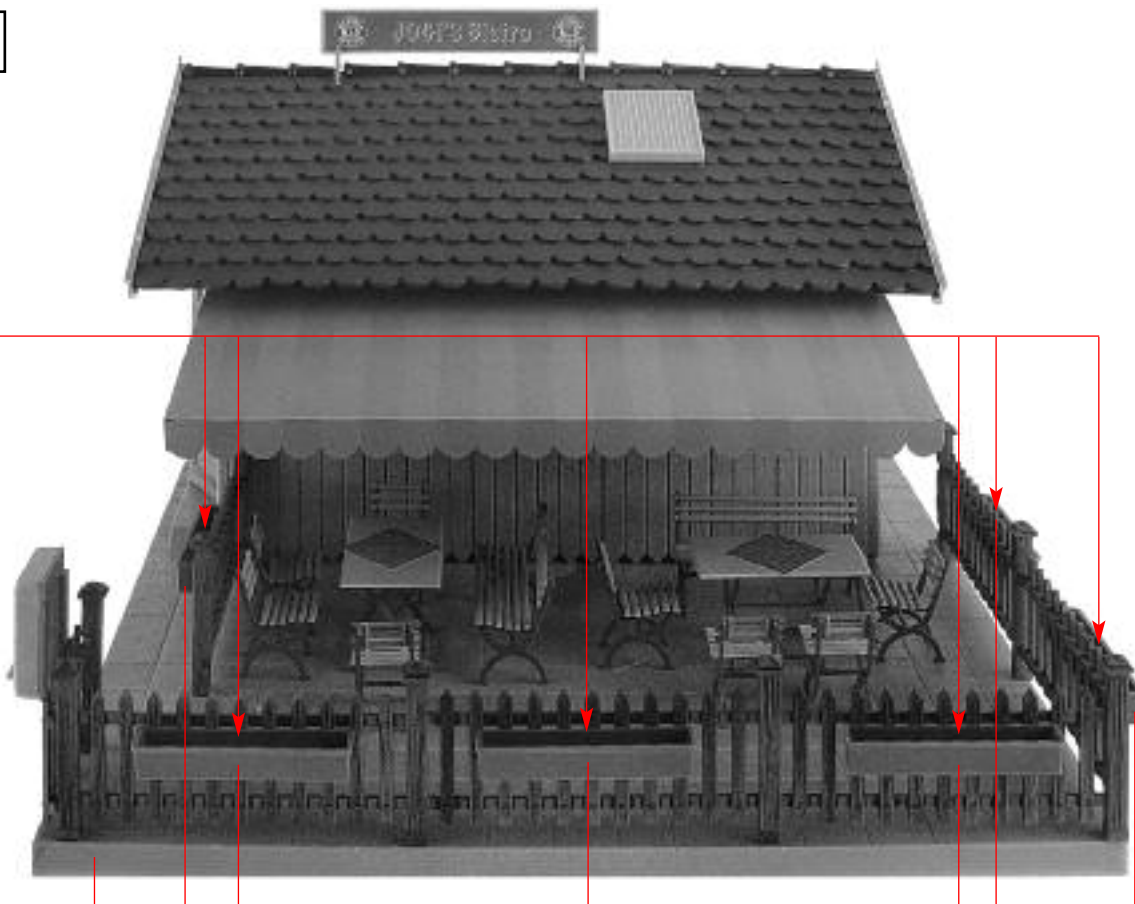

n

m

02-18

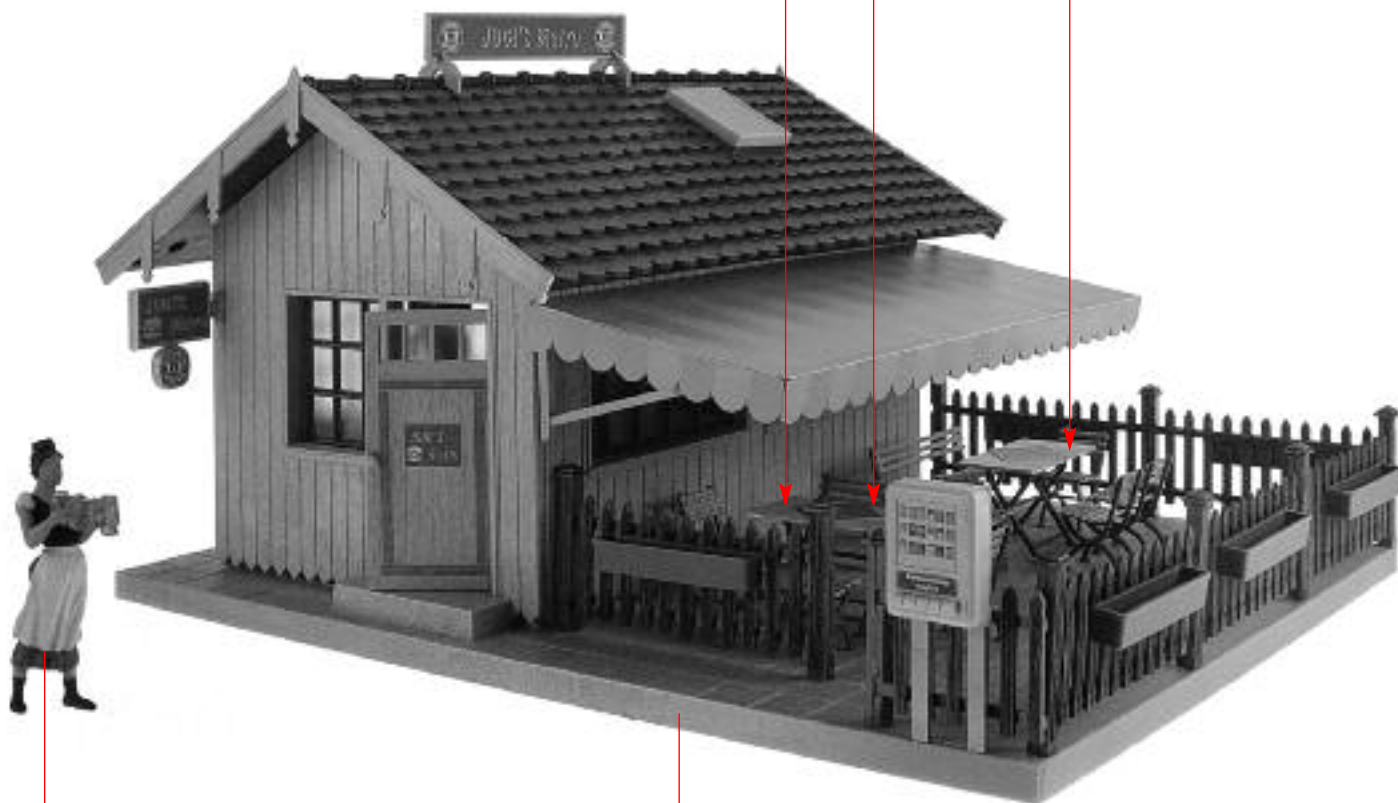
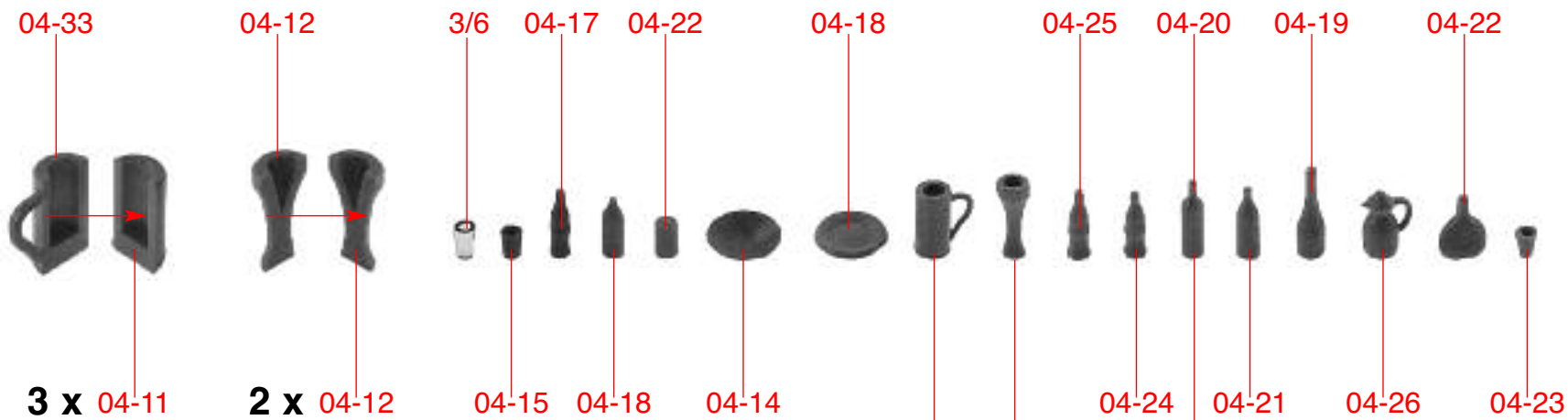

o

Inhalt	Tüte	Contents	bag
Contenu	sachet	Inhoud	zakje

n